

# **Models of Intellectual Capital Valuation: A Comparative Evaluation**

**Herman A. van den Berg**

## Table of Contents

Abstract.....	4
Introduction .....	5
Importance of Measuring Intellectual Capital.....	7
Socio-Economic Significance .....	7
Significance to the Firm.....	7
Development of the IC Concept.....	8
Commonly Known IC Measurement Models.....	8
Economic Value Added (EVA™) .....	9
Origin.....	9
Concepts .....	10
Attributes.....	10
Market Value Added (MVA).....	11
Origin.....	11
Concepts .....	12
Attributes.....	13
Tobin's Q Ratio.....	14
Origin.....	14
Concepts .....	14
Attributes.....	14
Norton and Kaplan's Balanced Score Card.....	15
Origin.....	15
Concepts .....	16
Attributes.....	17
Skandia's IC Navigator .....	17
Origin.....	17
Concepts .....	18
Attributes.....	19
Intellectual Capital Services' IC-Index™.....	20
Origin.....	20

Concepts .....	20
Attributes and Issues .....	21
The Technology Broker's IC Audit.....	22
Origin.....	22
Concepts .....	22
Attributes and Issues .....	23
Sveiby's Intangible Asset Monitor (IAM).....	23
Origin.....	23
Concepts .....	24
Attributes.....	25
Real Option Theory.....	25
Origin.....	25
Concepts .....	26
Attributes.....	26
Citation-weighted Patents .....	27
Origin.....	27
Concepts .....	27
Attributes.....	28
Model Classification Summary .....	29
References .....	30

## Abstract

Accounting, as it is currently practiced, has lost much of its ability to inform as businesses have become more and more knowledge intensive. Intangible assets are now variously estimated to currently constitute 60-75 percent of corporate value, on average (Lev, 2002). Research to date has yet to conclude how best to measure this intellectual capital (Brennan & Connell, 2000). Current debates about intellectual capital are part of the search for a methodology to measure the knowledge base of a firm (Power, 2001). This is critical since a failure to properly conceptualize the nature and value of knowledge assets condemns firms and whole economies to fight competitive battles with outdated weapons and tactics (Boisot, 1998).

The purpose of this paper is to present a comparative evaluation of some of the most commonly known intellectual capital (IC) models. Given the recent proliferation of IC models, it is fitting to classify the models and review their individual strengths and weaknesses.

The models to be evaluated include Stern Stewart's Market Value Added (MVA) and Economic Value Added (EVA™), Tobin's Q Ratio, Norton and Kaplan's Balanced Score Card, Skandia's IC Navigator, Intellectual Capital Services' IC-Index™, The Technology Broker's IC Audit, Sveiby's Intangible Asset Monitor (IAM), Citation-weighted Patents, and Real Option Theory. Dimensions of model classification will include temporal orientation, system dynamics, and causal direction.

"The present state of the nations is the result of the accumulation of all discovers, inventions, improvements, perfections and exertions of all generations which have lived before us: they form the **intellectual capital** of the present human race..." Friedrich List, 1841.

## Introduction

There are a growing number of methodologies for the measurement of intellectual capital (IC) at the firm level. The fact that the list is growing is perhaps a testament to both the difficulty of encapsulating something rather amorphous, the importance of doing so, and the tenacity with which pioneers in the field have tackled the subject. The challenge for academics is to frame the phenomenon using extant theories in order to develop a more rigorous conceptualization (Choo & Bontis, 2002). The purpose of this paper is to compare the most commonly known IC models as a first step towards meeting that challenge. Given the recent proliferation of IC models, it is appropriate to review the models and classify them according to their temporal orientation, system dynamics, and causal direction characteristics.

For temporal orientation, each model will be examined to determine whether it provides a historic report of performance, or measurements designed to manage future firm performance. Future oriented measurements are preferred over historic reports because they provide information that can be incorporated into decision-making, while the retrospective reports present no such opportunity.

For system dynamics, each model will be examined to determine whether it has a stock or resource focus versus a flow or process focus. Both stocks or balance sheet amounts, and flows affecting stocks are important to the management of a firm.

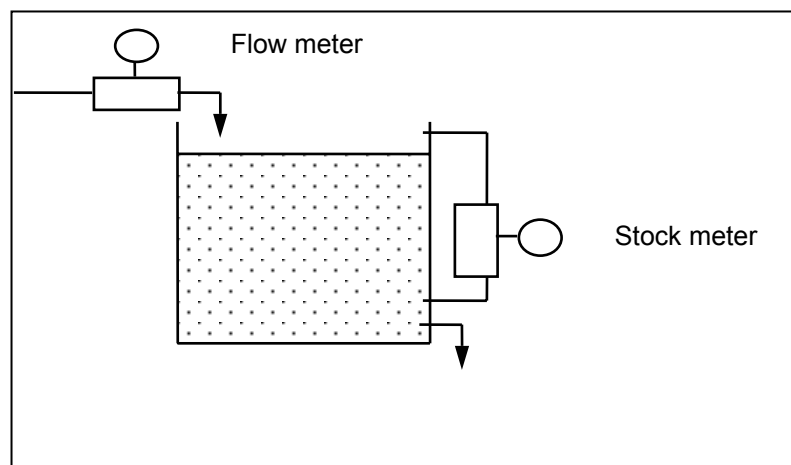

Figure 1: System Dynamics.

Unfortunately, many organizations focus on primarily or exclusively on the stocks or resources because they are relatively easy to measure. According to Roos, managers must also focus on measuring the transformation process or flow, which is more complicated but also more useful. According to Roos, “There is no correlation between how much you know and how good you are at transforming that knowledge into something useful for somebody else” (Chatzkel, 2002). The measurement of growth, or the rate of change of a flow, could also be important to the management of a firm.

For causal direction each model will be examined to determine whether it has a cause or value-creating focus versus an effect or valuation focus. It is interesting to know both the cause and the financial-economic outcome of management decisions affecting intellectual capital. What is even more important from a scientific, business, and policy perspective is to be able to link a given effect to various causes.

The models will be categorized according to the following table:

Model	Temporal Orientation		System Dynamics		Causal Direction	
	Historic	Future	Stock	Flow	Cause	Effect

# Importance of Measuring Intellectual Capital

“Every Business Is an Information Business” (Tapscott, 1999)

## ***Socio-Economic Significance***

Markets of all types require information in order to function. Buyers must know what sellers are offering, or transactions are not likely to occur. If they do occur, prices will be higher than they otherwise need be in order to account for the risks that buyers assume when they are not well informed.

Various estimates indicate that intangible assets currently constitute 60-75 percent of corporate value, on average. The socially harmful consequences of the failure to account properly for those assets, and disclose their attributes are numerous and very significant. They include (Lev, 2002):

1. Using intangibles for widespread manipulation of financial information,
2. Excessive gains to corporate insiders from trading the stock of their companies,
3. High volatility of stock prices, and
4. Excessive cost of capital to intangible-intensive companies, hindering innovation and growth.

Economic prosperity rests upon knowledge and its useful applications (Teece, 1998). There is much to support the assertion that IC is instrumental in the determination of enterprise value and national economic performance (Petty & Guthrie, 2000).

## ***Significance to the Firm***

Today, the nature and performance consequences of the strategies used by organizations to develop, maintain, and exploit knowledge for innovation, constitute an important topic in the field of business strategy (Choo & Bontis, 2002).

Intellectual capital management has been found to be important for a company's long-term success. Firms managing their intellectual capital outperform other companies (Brennan & Connell, 2000).

Debate no longer centers on whether or not knowledge assets exist, but on their measurement. Firms need to answer such questions as: Are returns on R&D satisfactory? Are patents worth renewing? Those failing to address these questions will ultimately lose out to competitors that learn to measure, manage and leverage their knowledge assets (Mintz, 1999).

## Development of the IC Concept

The development of intellectual capital reports, can be traced back to the desire for individuals working with or within businesses to improve their understanding of what comprised the value of the business so as to manage better those things that generate value (Petty & Guthrie, 2000).

The formation of the discourse on intellectual capital is predicated upon the assumption that the traditional double-entry bookkeeping system does not reflect emerging realities. It is an inadequate tool for measuring the value of corporations whose value lies mainly in their intangible components (Salzer-Mörling & Yakhlef, 1999).

The limitations of the existing financial reporting system for capital markets and other stakeholders have motivated an evolving dialogue on finding new ways to measure and report on a company's intellectual capital. The product of this dialogue is a plethora of new measurement approaches that all have the aim, to a greater or lesser extent, of synthesising the financial and non-financial value-generating aspects of the company into one external report (Petty & Guthrie, 2000).

## Commonly Known IC Measurement Models

The plethora of theories, models, and methods advanced for understanding and measuring IC suggests that there is no generally accepted theoretical model for understanding IC (Petty & Guthrie, 2000).

The following ten models will be examined:

- Economic Value Added (EVA™)\*
- Market Value Added (MVA)\*
- Tobin's Q Ratio\*
- The Balanced Score Card
- Skandia's IC Navigator
- Intellectual Capital Services' IC-Index™
- The Technology Broker's IC Audit
- Sveiby's The Intangible Asset Monitor (IAM)
- Real Option Theory
- Citation-weighted Patents

\*While MVA, EVA™, and Tobin's Q Ratio do not directly measure IC, they were early responses to the fact that book valuations of the firm as supplied by accounting were lacking in valuable information.

## ***Economic Value Added (EVA™)***

### **Origin**

There is a long-standing financial theory that says that a business creates value only when its returns exceed its cost of debt and equity capital. The basic metric for measuring value creation is economic profit. Economic profit measures net profit after deducting a charge to account for the cost of capital utilized to generate this profit (INSEAD).

EVA™ is not a new discovery. An accounting performance measure called residual income is defined to be operating profit subtracted with capital charge. EVA™ is thus one variation of residual income with adjustments to how one calculates income and capital (Mäkeläinen, 1998).

One of the earliest to mention the residual income concept was Alfred Marshall in 1890. Marshall defined economic profit as total net gains less the interest on invested capital at the current rate (Wallace, 1997). The idea of residual income appeared first in accounting theory literature early in the last century by Church in 1917 and by Scovell in 1924 and appeared in management accounting literature in the 1960s (Dodd & Chen, 1996).

One of the best known economic profit metrics is Stern Stewart & Company's Economic Value Added (EVA™). EVA™ is a trademarked variant of residual income that Stern Stewart & Company has marketed to be used instead of earnings or cash from operations as a measure of both internal and external performance (Biddle, Bowen, & Wallace, 1997).

The term EVA™ received little attention until a September, 1993 article in Fortune magazine provided a detailed description of the EVA™ concept, Stern Stewart practice, and successful EVA™ adoptions by major corporations in the US. Similar Performance measures marketed by competing firms include cash-flow return on investment (CFROI) by Boston Consulting Group's HOLT Value Associates, shareholder value added (SVA) by Rappaport's Corporate Performance Systems, Adjusted economic value added (AEVA) by de Villiers, Refined economic value added (REVA) by Bacidore et al., discounted economic profits (EP) by Marakon Associates, and economic value management (EVM) by KPMG (Bacidore, Boquist, Milbourn, & Thakor, 1997; Biddle et al., 1997; de Villiers, 1997; Mäkeläinen, 1998).

## Concepts

The EVA™ method of value measurement has its basis in traditional accounting. As defined by Stern Stewart, EVA™ is the difference between a company's net operating income after taxes and its cost of capital of both equity and debt (Chen & Dodd, 2001).

Calculating economic profit from accounting income is not easy; it requires hundreds of adjustments. For example, under traditional accounting cash disbursed for research and development (R & D) is expensed, but in arriving at economic income R & D would be capitalized since it provides a future economic benefit. The list of adjustments from accounting to economic is extensive (Evans, 1999).

### An equation for calculating EVA™

$EVA^{\text{TM}} = \text{Residual Income (RI)} + \text{Accounting Adjustments (AcctAdj)}$

where:

$RI = \text{Net Operating Profits After Taxes (NOPAT)} - \text{Capital Charge (CapChg)}$

$NOPAT = \text{Earnings Before Extraordinary Items (EBEI)} + \text{After Tax Interest (ATInt)}$

$EBEI = \text{Cash Flow from Operations (CFO)} + \text{Accruals}$

$ATInt = \text{Net Interest Expense} \times (1 - \text{Tax Rate})$

CapChg = the charge for use of capital. It includes interest on the debt plus a charge for the equity capital based on a cash equivalent equity multiplied by a cost of equity.

Figure 2: EVA™ (Chen & Dodd, 2001; Evans, 1999)

In summary, the goal in calculating EVA™ is to arrive at earnings that are close to cash and compare this return to a capital base that is also expressed in cash equivalent terms.

## Attributes

### Temporal Orientation

There is an implicit assumption in using EVA™ that the future value of a firm is entirely a function of historic activity. Equity valuation is ultimately the discounted present value of future equity cash flows, and EVA™ is ultimately still based on historic events (Biddle et al., 1997).

### System Dynamics

EVA™ is a measurement of a stock of value (added) even though it is typically measured over a period of one year. There is no indication of the rate of change

in value addition during the year. Comparing EVA™ at the end of two different periods could result in an average rate of change of EVA™ between those two points in time.

### Causal Direction

Empirical evidence does not appear to support the theory that EVA™ is linked to share value. Biddle et al examined Stern Stewart’s claim that EVA™ is superior to earnings in association with stock returns. They discovered that there is little evidence to support the Stern Stewart claim that EVA is superior to earnings in its association with stock returns or with firm values. In no case did EVA™ significantly outperform Earnings Before Extraordinary Items (EBEI) in tests of relative information content. On the contrary, in most cases the evidence suggests that earnings outperformed EVA™. Further, while the charge for capital and Stern Stewart’s adjustments for accounting ‘distortions’ show some marginal evidence of being incrementally important, this difference did not appear to be economically significant (Biddle et al., 1997).

Chen and Dodd examined the value relevance of three profitability measures: operating income, residual income, and economic value added (EVA™). Their study found that all three profitability measures have little information content in terms of value-relevance. Contrary to the claim of EVA™ advocates, the data did not support the assertion that EVA™ is the best measure for valuation purposes. Results are consistent with prior studies that find accounting-based information explains little of the variation in stock returns between firms. Relatively low R<sup>2</sup>s suggest that over 90% of the variation appears to be attributable to non-earnings-based information. This suggests that if firms desire to more closely align organizational metrics with stock value, a measurement paradigm other than EVA™ will have to be developed (Chen & Dodd, 2001).

Model	Temporal Orientation		System Dynamics		Causal Direction	
	Historic	Future	Stock	Flow	Cause	Effect
EVA™	✓		✓			

### Market Value Added (MVA)

#### Origin

Market Value Added (MVA), like EVA™, also derives its origin in the concept of economic profit as developed in the 19<sup>th</sup> century. One way of looking at MVA is to consider it the sum of initial capital invested and the economic profit or residual income or EVA™ accumulated over time.

## Concepts

MVA is the difference between the market value of a company (both equity and debt) and the capital that lenders and shareholders have entrusted to it over the years in the form of loans, retained earnings and paid-in capital. As such, MVA is a measure of the difference between "cash in" (what investors have contributed) and "cash out" (what they could get by selling at today's prices). If MVA is positive, it means that the company has increased the value of the capital entrusted to it and thus created shareholder wealth. If MVA is negative, the company has destroyed wealth (*Performance Rankings*, 1999).

By maximizing the spread between the cash that a firm's investors have put into the business since the start up of the company and the present value of the cash that they could get out of it by selling their shares, corporate managers maximize the wealth of the company's shareholders relative to other uses of capital (Bontis et al., 1999).

**MVA = Market Value of Debt + Market Value of Equity - Total Adjusted Capital**

The total outstanding number of shares multiplied by the share price is the market value of a company's equity. Similarly, the total outstanding debt of a company multiplied by the market value of that debt is the market value of a company's debt. Total adjusted capital is the balance sheet total adjusted for a few accounting peculiarities such as LIFO reserve, notes payable, present value of operating leases, deferred taxes and the total amount of goodwill expensed to date, using both an operating and financing approach (Evans, 1999).

MVA is also used as a way of benchmarking market performance between companies. In order to have a comparable MVA, a standardized MVA is calculated by dividing the change in MVA by the adjusted equity value at the beginning of the year (Evans).

**Standardized MVA = Change in MVA for the Year / Adjusted Equity at Beginning of Year**

### Example MVA and Standardized MVA Calculation

ABC Corporation has 100,000,000 shares of common stock outstanding with a market price of \$25 per share. ABC has reviewed the book values of all of the debt and equity issued and adjusted it to a cash equivalent value of \$2,400,000,000. In arriving at the \$2,400,000,000 ABC reversed out the negative affects on equity, such as extraordinary losses. Last year ABC had a Market Value Added of \$75,000,000.

Market Value of Equity = 100,000,000 x \$25 = \$2,500,000,000

Total Adjusted Capital = \$2,400,000,000

Difference is Market Value Added = \$100,000,000

Last Year's MVA = \$75,000,000

Change in MVA = \$25,000,000

Standardized MVA: \$25,000,000 / \$ 2,400,000,000 = 1.04%

Figure 3: MVA (Evans, 1999).

## Attributes

### Temporal Orientation

MVA measures are entirely the result of historic activity. However, it is fairly easy to obtain a current estimate for a firm whose shares and debt trade in public markets, and who have recently published financial statements.

### System Dynamics

MVA is by definition a measurement of a stock of value: the difference between a market valuation of a firm and its book value at a given point in time. There is no rate of change or flow component. Comparing MVA at the end of two different periods could result in an average rate of change in MVA between the two points in time.

### Causal Direction

Although it could be argued that MVA provides a cumulative measure of human value-adding activity, there does not appear to be any empirical evidence linking to MVA to any underlying cause. In addition, it would be a circular argument to claim that MVA is a cause of increased shareholder value.

Model	Temporal Orientation		System Dynamics		Causal Direction	
	Historic	Future	Stock	Flow	Cause	Effect
MVA	✓		✓			

## **Tobin's Q Ratio**

### **Origin**

The Q Ratio, or  $q$ , is the value of capital relative to its replacement cost (Tobin, 1969). Tobin, a Nobel Prize winning economist, developed it as a measure to help predict investment decisions independent of macroeconomic factors such as interest rates. Tobin's Q was not developed as a measure of intellectual capital, but Federal Reserve chairman Alan Greenspan has noted that high Q and market-to-book ratios reflect the value of investments in technology and human capital (Stewart, 1997).

### **Concepts**

Tobin's Q is essentially the same as the market-to-book ratio except that Tobin used replacement cost of tangible assets rather than book value of tangible assets in calculation. The use of replacement cost neutralizes many of the difficulties with the market-to-book ratio (Luthy, 1998).

<b>Tobin's Q Ratio</b>
$Q = \text{Market Value} / \text{Asset Value}$

Figure 4: Tobin's Q Ratio (Luthy, 1998; Mäkeläinen, 1998).

A positive Q Ratio value can be ascribed to the intangible value of intellectual capital which is not captured by traditional accounting systems (Luthy, 1998).

If the Q Ratio is less than 1, an asset is worth less than the cost of replacing it, and it is unlikely that a company will buy more assets of that kind. If on the other hand, Q Ratio is greater than 1, companies are likely to invest in similar assets that are worth more than their replacement cost (Stewart, 1997).

Using Tobin's Q instead of market-to-book ratios neutralizes the effects of different depreciation policies which vary from company to company and country to country (Roos, Roos, Edvinsson, & Dragonetti, 1998; Stewart, 1997). Tobin's Q is most revealing when like companies are compared over a period of several years (Stewart, 1997).

### **Attributes**

#### **Temporal Orientation**

Tobin's Q measures the result of human activity over time as expressed in the market value of a firm. Although it is a fairly onerous exercise to estimate the replacement cost of the tangible assets used in the denominator of the

calculation, current market values a firm whose shares in public markets, are relatively easy to obtain.

### System Dynamics

Tobin’s Q is a ratio of two stocks of value, a market valuation of a firm and the replacement value of its assets. It is a measure at a point in time and there is no rate of change component. Comparing the Q ratio at two points in time could result in an average rate of change between those two points.

### Causal Direction

Despite Greenspan’s assertion that high Q ratios reflect the value of investments in technology and human capital, there does not appear to be any empirical evidence linking to Tobin’s Q to any underlying cause. In addition, since the Q ratio is based on share prices, it would be a circular argument to claim that it is a cause of increased shareholder value.

Model	Temporal Orientation		System Dynamics		Causal Direction	
	Historic	Future	Stock	Flow	Cause	Effect
Tobin’s Q	✓		✓			

## ***Norton and Kaplan’s Balanced Score Card***

### Origin

The Balanced Scorecard (BSC) was created by Robert Norton and David Kaplan to provide managers with a translation of their organization’s mission and strategy into a comprehensive set of performance measures that provides the framework for a strategic measurement and management system. The BSC retains an emphasis on achieving financial objectives, but also includes the performance drivers of these financial objectives. In addition to tracking financial results, the BSC simultaneously monitors the progress in the building of the capabilities and acquiring of intangible assets for future growth (Kaplan & Norton, 1996).

The BSC was developed out of a recognition that the ability of a company to mobilize and exploit its tangible or invisible assets has become far more decisive than investing and managing physical, tangible assets. Managers, in their efforts to build long range competitive capabilities have been colliding with “the immovable object” of the historical cost-based accounting model (Kaplan & Norton, 1996).

## Concepts

The balanced scorecard suggests that we view the organization from four perspectives, and to develop metrics, collect data and analyze it relative to each of these perspectives.

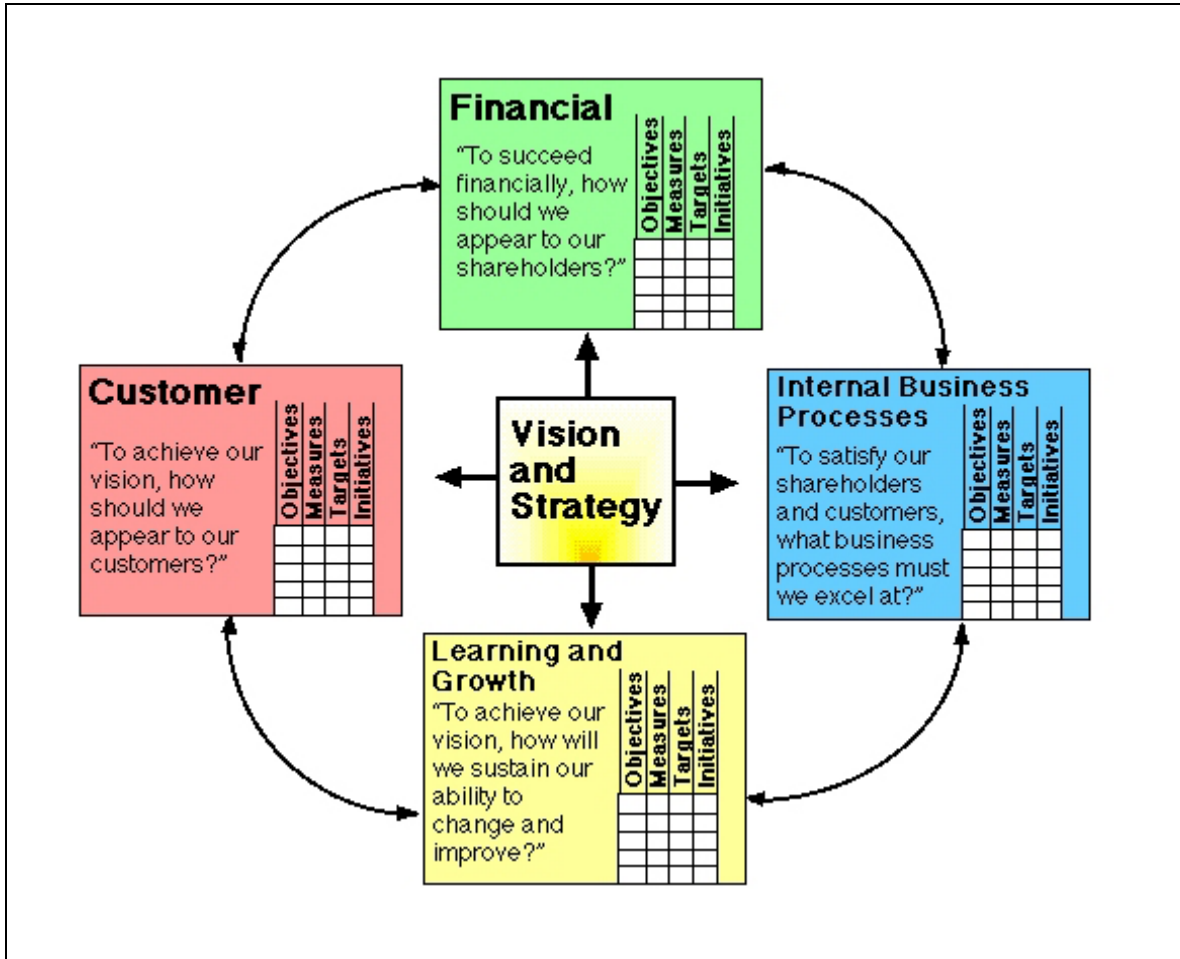

Figure 5: The Balanced Scorecard (Kaplan & Norton, 1996).

The 'balance' of the scorecard is between the external measures for shareholders and customers, and internal measures of critical business processes, innovation, and learning and growth. A 'balance' also exists between relatively objective outcome measures and subjective, judgemental measures of performance drivers (Kaplan & Norton, 1996).

## Attributes

### Temporal Orientation

The Balanced Scorecard collects the results of human activity over time and expresses them as both internal and external measures. Since the BSC compares actual results to predetermined targets, it has a reporting or historic orientation.

### System Dynamics

The Balanced Scorecard can include stock and flow measures or both. The determination of the measures and the types used is expected to be a function of the management's interpretation of the firm's strategy.

### Causal Direction

The principal premise on which the BSC concept is based is the view that a business strategy can be viewed as a set of hypotheses about cause-and-effect relationships (Banker, 2000). Recent research testing the validity of the BSC's claim to be a causal model of financial performance has found mixed empirical support, in contrast with much professional literature that has given the implied relation almost unqualified support (Malina, 2001). Some of the lack of empirical support may lie in the difficulty of isolating financial performance as a result of management's strategy selection ability and financial performance as a result of management's ability to the select the appropriate performance measures for a given strategy.

Model	Temporal Orientation		System Dynamics		Causal Direction	
	Historic	Future	Stock	Flow	Cause	Effect
BSC	✓		Can be included	Can be included	Lacking evidence	✓

## Skandia's IC Navigator

### Origin

The IC Navigator was developed at the Swedish financial services company Skandia by a team led by Leif Edvinsson (Edvinsson & Malone, 1997). It incorporates the presumption that intellectual capital represents the difference between market and book value of the company (Edvinsson & Malone, 1997; Luu, Wykes, Williams, & Weir, 2001).

Despite the weaknesses of Skandia's IC Navigator, most researchers agree that Skandia's considerable efforts to create a taxonomy to measure a company's intangible assets... emboldened others to look beyond traditional assumptions of

what creates value for organizations” (Bontis, 2001). Petty concludes, “Edvinsson's work was very much about the process” (Petty & Guthrie, 2000).

## Concepts

The total Market Value of a firm is equal to its Financial Capital plus its Intellectual Capital. The components of IC are Human Capital, Structural Capital. Structural Capital can be deconstructed into Organizational Capital and Customer Capital. Organizational Capital can in turn be deconstructed into Innovation Capital and Process Capital (Edvinsson & Malone, 1997).

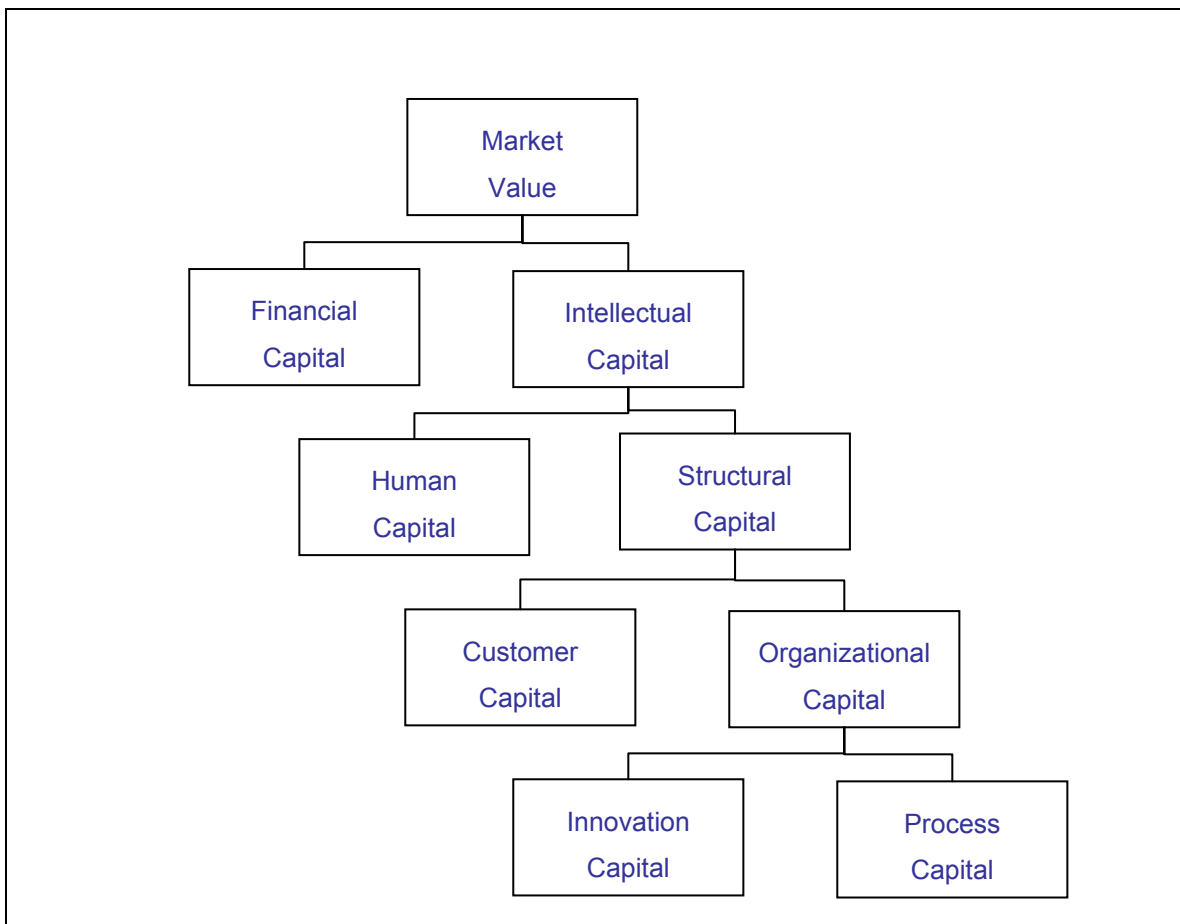

Figure 5: Skandia Market Value Scheme (Edvinsson & Malone, 1997).

Organizational Intellectual Capital is the overall common IC measure of a company. It is calculated by multiplying an efficiency coefficient, ( $i$ ), by an absolute monetary IC measure, ( $C$ ). The efficiency coefficient is the arithmetic mean of the “Intellectual Capital Coefficient of Efficiency Indices”, a set of percentages derived by culling out redundancies and applying some subjective judgement (Edvinsson & Malone, 1997). (However, the example given on page

188 does not appear to be calculated in this way). The absolute monetary measure, (C), is equal to the sum of “about two dozen indices” measured in monetary terms (Edvinsson & Malone, 1997).

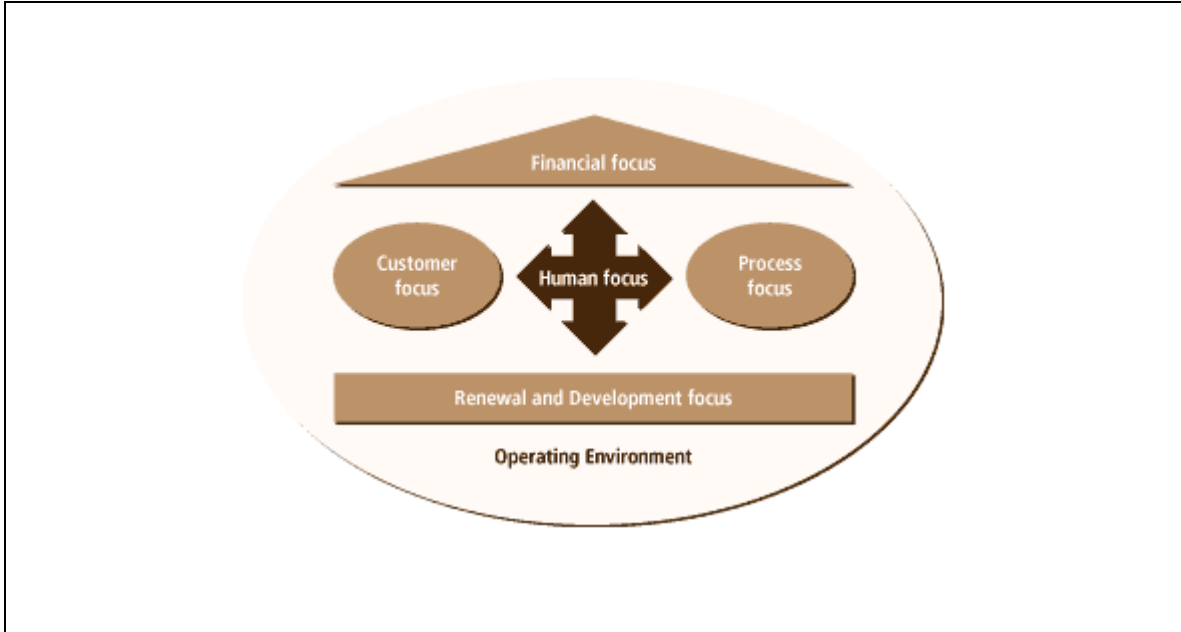

Figure 6: Skandia Navigator (Edvinsson & Malone, 1997).

The Skandia Navigator approach takes into account the same set of financial, operational, and customer concerns as the Balanced Scorecard. But, it makes more explicit the need to consider the organization, its structure and processes for nurturing its employees (Shand, 1999).

## Attributes

### Temporal Orientation

The Intellectual Capital Report is a historic document which gives an account of numerous “indices” from the Financial, Customer, Process, Renewal and Development, and Human Focuses.

### System Dynamics

The IC Report is generally composed of stock measures, but does include some financial flow variables such as revenue, expenses, profit, and return on assets. The expense flow variables are often divided by a denominator such as the number of employees and then considered outside of the Financial Focus.

### Causal Direction

The link between reported measures and organizational and investor outcomes requires investigation (Boudreau & Ramstad, 2001). There does not appear to be any evidence that using the IC Navigator leads to better economic performance.

Model	Temporal Orientation		System Dynamics		Causal Direction	
	Historic	Future	Stock	Flow	Cause	Effect
IC Nav.	✓		Mostly	A few included	Lacking evidence	✓

### Intellectual Capital Services' IC-Index™

#### Origin

The IC-Index model was created by Göran and Johan Roos of London-based Intellectual Capital Services.

#### Concepts

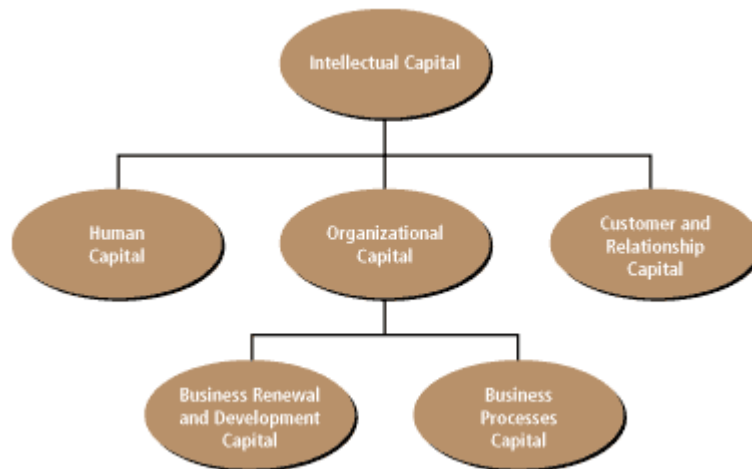

Figure 7: IC-Index Intellectual Capital Tree (Roos et al., 1998).

Finding that the importance of specific components of the IC-Index Intellectual Capital Tree varied from firm to firm, Roos & Roos honed in on four high level categories as displayed in Figure 8.

<b>Relationship Capital Index</b> <ul style="list-style-type: none"> <li>• Growth in number of relationships</li> <li>• Growth in trust</li> <li>• Customer retention</li> <li>• Distribution channels productivity and quality</li> </ul>	<b>Human Capital Index</b> <ul style="list-style-type: none"> <li>• Fulfilment of key success factors</li> <li>• Value creation per employee</li> <li>• Training efficiency and effectiveness</li> </ul>
<b>Infrastructure Capital Index</b> <ul style="list-style-type: none"> <li>• Efficiency</li> <li>• Effectiveness</li> <li>• Key success factors utilisation</li> <li>• Distribution efficiency</li> </ul>	<b>Innovation Capital Index</b> <ul style="list-style-type: none"> <li>• Ability to generate new business</li> <li>• Ability to generate good products</li> <li>• Growth</li> <li>• Ability to improve productivity</li> </ul>

Figure 8: Hierarchy of Categories in the IC Index (Roos et al., 1998).

Developing measures within these categories requires a three stage process:

1. A critical review of existing indicators.
2. Development of indicators that represent the flows between different IC categories.
3. Develop a hierarchy of IC indices.

Each of these indices are in turn aggregated into a single index that can be used to compare the same unit over time, or with other business units (*The IC Index - customer capital and the knowledge economy*, 2000)

## Attributes and Issues

### Temporal Orientation

The IC-Index is a historic document which gives an account of numerous “indices” and an ultimate single Index number which can be compared from period to period

### System Dynamics

The IC-Index is a stock variable as it measures the IC stock at a given point in time (O'Brien, 2002).

### Causal Direction

There are anecdotal claims that the IC-Index can predict how monetary investments in different types of capital will eventually make their way into

products and sales. For example, Apion, Ltd. is reported to have established a strong correlation between its various intellectual capital investments and cash flows (Shand, 1999). Unfortunately, empirical evidence is lacking.

Model	Temporal Orientation		System Dynamics		Causal Direction	
	Historic	Future	Stock	Flow	Cause	Effect
IC-Index	✓		Mostly	A few included	Lacking evidence	✓

### The Technology Broker's IC Audit

#### Origin

Brooking designed this model to place a definitive dollar value of a firm's IC.

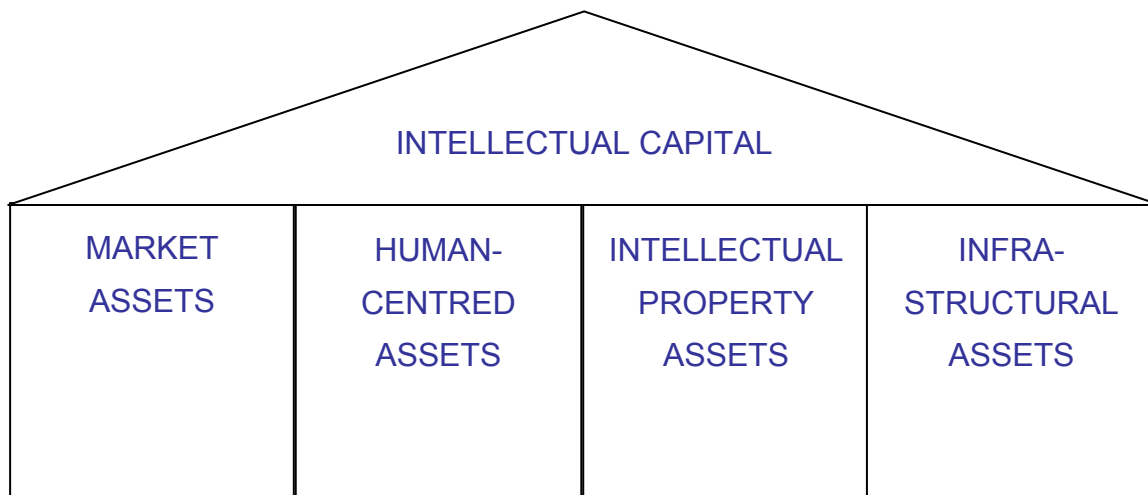

Figure 9: The Components of Intellectual Capital (Brooking, 1998)

#### Concepts

Market assets consist of such things as brands, customers, distribution channels, and business collaborations. Intellectual property assets include patents, copyrights, and trade secrets. Human-centered assets include education and work-related knowledge and competencies. Infrastructure assets include management processes, information technology systems, networking, and financial systems (Brooking, 1998).

It works as a diagnostic, prompting managers to develop IC indicators initially through a 20 question survey followed by a further 158 questions touching on a range of issues regarding intangible assets such as brand equity, knowledge management processes, and existing research and development (R&D) measures. The more affirmative the responses in these areas, the healthier the firm’s IC focus is deemed to be. Following the survey, a dollar value for the IC is calculated using either a cost approach, a market approach, or an income approach (O'Brien, 2002).

## Attributes and Issues

### Temporal Orientation

The Intellectual Capital Audit is a historic document designed to measure a firm’s IC at a specific point in time, and makes no prediction of the future.

### System Dynamics

The IC Audit has an asset or stock focus.

### Credibility and Causal Direction

There does not appear to be any empirical evidence that using the IC Audit leads to better economic performance.

Model	Temporal Orientation		System Dynamics		Causal Direction	
	Historic	Future	Stock	Flow	Cause	Effect
IC Audit	✓		Mostly	A few included	Lacking evidence	✓

## Sveiby’s Intangible Asset Monitor (IAM)

### Origin

Sveiby’s Intangible Asset Monitor developed out of his experience as a partner and manager of a financial weekly. While working there, he realized that the firm’s traditional financial statements “were a joke” and that most of the value of the firm lay in its “invisible knowledge-based assets”. Nonaka and Takeuchi’s four modes of knowledge conversion formed part of the intellectual underpinning of the Intangible Asset Monitor (Sveiby, 1997).

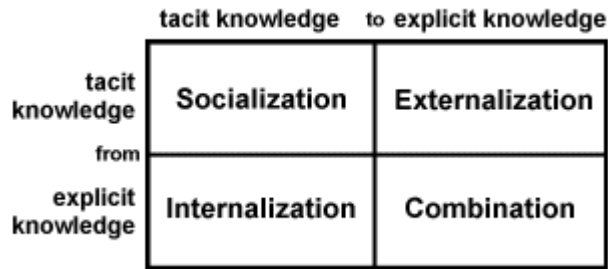

Figure 10: Four Modes of Knowledge Conversion (Nonaka & Takeuchi, 1995).

### Concepts

The total market value of a company consists of its visible equity and three kinds of intangible assets (Sveiby, 1997).

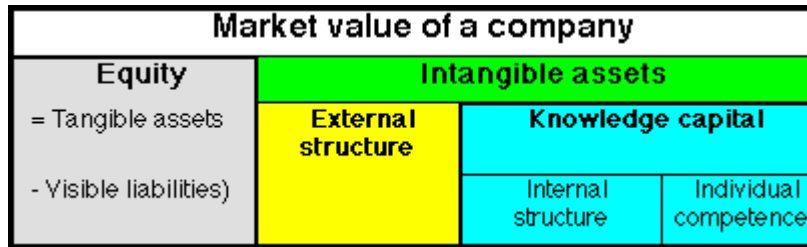

Figure 11: Market Value of a Company (Sveiby, 1997).

Total market value of a company consists of its visible equity and three kinds of intangible assets. The visible equity is the book value of the firm. The intangible assets are categorized as either external structure or knowledge capital. The external structure consists of brands, and customer and supplier relations. Knowledge capital is comprised of internal structure and individual competence. The internal structure is composed of the organization's management, legal structure, manual systems, attitudes, R&D, and software. Individual competence includes education and experience (Sveiby, 1997).

## Attributes

### Temporal Orientation

	External Structure	Internal Structure	Competence
<b>Growth/Renewal</b>	Profit/customer Growth in market share Satisfied customer index	IT investments R&D investment	Number of years' education Share of sales from competence-enhancing customers
<b>Efficiency</b>	Sales per professional Profit per customer	Support staff % Values	Value added/employee
<b>Stability</b>	% large companies Devoted customer (repeat orders)	Turnover "Rookie" ratio	Professional turnover Relative pay

Figure 12: An Example of an Intangible Assets Monitor (Sveiby, 1997).

The Intangible Assets Monitor is a historic document which reports on a number of financial and non-financial measures. These measures score a firm's ability at growth/renewal, efficiency, and stability applied across the three forms of intangible assets, external structure, internal structure, and competence.

### System Dynamics

The IAM is generally composed of stock measures, but does include some flow-related variables such as growth in revenue and growth in sales per administrative staff (Sveiby, 1997).

### Causal Direction

There does not appear to be any evidence that using the Intangible Assets Monitor leads to better financial-economic performance.

Model	Temporal Orientation		System Dynamics		Causal Direction	
	Historic	Future	Stock	Flow	Cause	Effect
IAM	✓		Mostly	A few included	Lacking evidence	✓

## Real Option Theory

### Origin

Real Option Theory provides an approach which values the opportunities arising from intellectual capital. A real option is one that is based on non-financial assets and, unlike a financial option, the underlying asset is non-tradable. It applies the same techniques and variables as the Black-Scholes model on which financial options are based, but uses non-financial inputs. The term, real option, was

coined in 1977 by Stewart C. Meyers of Massachusetts Institute of Technology. Its earliest applications were in oil, gas, copper, and gold, and companies in such commodity businesses remain some of the biggest users (Luu et al., 2001).

The value of the real option depends on the idea developed by the firm's R&D activity, the risk of the R&D activity, and the speed with which it is completed and introduced on the market in relation to similar actions of competitors (Johnson, Neave, & Pazderka, 2001).

## **Concepts**

The goal of business is to direct the firm's resources to those activities which provide the highest economic value for the owners of the firm. The valuation and choice of new investments for a firm is more complicated than the capital market since within the firm there is no market for assets. With no market to provide a "fair" estimate, managers must estimate value (Phelan, 1997).

According to Simon (Beaver, 2002):

- we do not have perfect knowledge about all future states of the world;
- we do not possess the cognitive skill to determine appropriate actions for the states which we can perceive; and
- we cannot foresee all the possible consequences of actions we do eventually choose to take.

The use of real option theory provides one solution to our human inability to forecast complex or distant future events accurately (Phelan, 1997). The real options approach recognizes that the boundaries of firms are fluid with respect to adopting different kinds of projects, and attempts to value the consequences of their possible adoption (Johnson et al., 2001).

## **Attributes**

### **Temporal Orientation**

The Real Option approach provides a perspective on the future that assists manager in making decisions. This is a refreshing break from previous attempts at capturing the historic value of IC.

### **System Dynamics**

The Real Option approach facilitates the interchange of a stock measured in net present value with flows of future cash value.

## Causal Direction

There is no known empirical evidence that the use of Real Option valuation of IC leads to improved financial-economic performance.

Model	Temporal Orientation		System Dynamics		Causal Direction	
	Historic	Future	Stock	Flow	Cause	Effect
Real Op.		✓	Both	Both		

## Citation-weighted Patents

### Origin

Schmookler and Scherer were two of the earliest researchers to use patent data in the economic analysis of technological change in the 1960s. The arrival of publicly available computerized patent information in the 1980s led to a second wave of econometric research using patent citations to increase the information content of the data (Hall, Jaffe, & Trajtenberg, 2001).

The distribution of the value of patented innovations is extremely skewed. A few patents are very valuable, but most are close to valueless. Therefore the number of patents held by a firm is not highly correlated to the sum of the value of those patents (Hall et al., 2001).

### Concepts

A patent is a temporary legal monopoly granted to inventors for the commercial use of an invention. The technological antecedents of patented inventions are identified as references or citations in the patent documentation (Hall et al., 2001).

Research using patent citations to measure IC is based on the following assumptions (Hall et al., 2001):

1. Stock market investors hold the rational expectation that the present value of a firm's future profits varies with its stock of knowledge,
2. Valuable technological knowledge within the firm tends to generate patents that future researchers build on and therefore cite when doing their own innovation.

The working hypothesis that flows from these assumptions is that citations are an indicator of the (private) value of the associated patent right, and are therefore correlated with the market value of the firm because investors value the firm's stock of knowledge (Hall et al., 2001).

There is considerable evidence that self citations (citations to patents assigned to the same firm as the citing patent) are worth about twice as much as ordinary citations, especially to smaller firms. It is not clear a priori what interpretation to give to these self citations. They should be less significant economically if they appear as a result of being well known within a firm or if they appear because of an inventor's desire to acknowledge colleagues. On the other hand, they may be an indication that a firm has a strong competitive position in a particular field and is able to successfully appropriate cumulative impacts while keeping spill over to competitors to a minimum (Hall et al., 2001).

## Attributes

### Temporal Orientation

Relative to the historic nature of most the other models of IC, the use of citation-weighted patents is ancient history. To the extent that other models rely on accounting data, they are never more than 18 months out of date. However, due to the ex post nature of citations data, the usefulness of citations in estimating the current value of intangible assets is limited. This is because the bulk of citations occur in the range of three to ten years after a patent is granted. To address this problem an expectations model will have to be developed (Hall et al., 2001; Shane & Klock, 1997).

### System Dynamics

The Citation-weighted Patent approach provides a partial measure of the stock of IC held by a firm.

### Causal Direction

There is some empirical evidence that the market value of a firm is in some part a function of the citations acknowledging the firm's patents.

Model	Temporal Orientation		System Dynamics		Causal Direction	
	Historic	Future	Stock	Flow	Cause	Effect
CWP	✓		✓		✓	

## Model Classification Summary

Model	Temporal Orientation		System Dynamics		Causal Direction	
	Historic	Future	Stock	Flow	Cause	Effect
EVA™	✓		✓			
MVA	✓		✓			
Tobin's Q	✓		✓			
BSC	✓		Can be included	Can be included	Lacking evidence	✓
IC Nav.	✓		Mostly	A few included	Lacking evidence	✓
IC-Index	✓		Mostly	A few included	Lacking evidence	✓
IC Audit	✓		Mostly	A few included	Lacking evidence	✓
IAM	✓		Mostly	A few included	Lacking evidence	✓
Real Op.		✓	Both	Both		
CWP	✓		✓		✓	

## References

- Bacidore, J. M., Boquist, J. A., Milbourn, T. T., & Thakor, A. V. (1997). The search for the best financial performance measure. *Financial Analysts Journal*, 53(3), 11-20.
- Banker, R. D. (2000). *A Contextual Study of Links between Employee Satisfaction, Employee Turnover, Customer Satisfaction and Financial Performance*. Dallas: University of Texas.
- Beaver, W. H. (2002). Perspectives on recent capital market research. *Accounting Review*, 77(2), 453-474.
- Biddle, G. C., Bowen, R. M., & Wallace, J. S. (1997). Does EVA(TM) beat earnings? Evidence on associations with stock returns and firm values. *Journal of Accounting & Economics*, 24, 301-336.
- Boisot, M. H. (1998). *Knowledge Assets: Securing Competitive Advantage in the Information Economy*. Oxford: Oxford University Press.
- Bontis, N. (2001). Assessing knowledge assets: a review of the models used to measure intellectual capital. *International Journal of Management Reviews*, 3(1), 41-60.
- Boudreau, J. W., & Ramstad, P. M. (2001). *Strategic I/O Psychology and Utility Analysis* (Final Chapter to appear in forthcoming Handbook). Ithaca: Center for Advanced Human Resource Studies, Cornell University.
- Brennan, N., & Connell, B. (2000). Intellectual capital: current issues and policy implications. *Journal of Intellectual Capital*, 1(3), 206-240.
- Brooking, A. (1998). *Intellectual Capital: Core Asset for the Third Millennium Enterprise*. London: International Thomson Business Press.
- Chatzkel, J. (2002). A conversation with Göran Roos. *Journal of Intellectual Capital*, 3(2), 96-117.
- Chen, S., & Dodd, J. L. (2001). Operating income, residual income and EVA: Which metric is more value relevant. *Journal of Managerial Issues*, 13(1), 65-89.
- Choo, C. W., & Bontis, N. (Eds.). (2002). *The Strategic Management of Intellectual Capital and Organizational Knowledge*. New York: Oxford University Press, Inc.
- de Villiers, J. (1997). The Distortions in Economic Value Added (EVA) Caused by Inflation. *Journal of Economics and Business*, 49(3), 285-300.
- Dodd, J. L., & Chen, S. (1996). EVA: A new panacea? *Business and Economic Review*, 42(4), 26-28.

- Edvinsson, L., & Malone, M. S. (1997). *Intellectual capital: realizing your company's true value by finding its hidden brainpower* (1st ed.). New York: HarperBusiness.
- Evans, M. H. (1999). *Creating Value through Financial Management* [Web site]. Retrieved, 2002, from the World Wide Web: <http://www.exinfm.com/training/pdfiles/course08.pdf>
- Hall, B. H., Jaffe, A., & Trajtenberg, M. (2001). *Market Value and Patent Citations: A First Look (August 2, 2001)*. Economics Department, University of California, Berkeley. Retrieved, from the World Wide Web: <http://repositories.cdlib.org/iber/econ/E01-304>
- The IC Index - customer capital and the knowledge economy* (2000). Retrieved, 2002, from the World Wide Web: <http://www.eccs.uk.com/resources/intellectual.asp>
- INSEAD. *Economic Profit Metrics*. Retrieved, 2002, from the World Wide Web: <http://www.insead.edu/mfv/metrics.htm>
- Johnson, L. D., Neave, E. H., & Pazderka, B. (2001). *Knowledge, Innovation and Share Value* (Framework Paper 01-11). Kingston: Queen's University.
- Kaplan, R. S., & Norton, D. P. (1996). *The Balanced Scorecard: Translating Strategy Into Action* [Electronic Book]. Harvard Business School Press. Retrieved, from the World Wide Web: [http://www.netlibrary.com/ebook\\_info.asp?product\\_id=7252](http://www.netlibrary.com/ebook_info.asp?product_id=7252)
- Lev, B. (2002). Response to your questions (from February 20, 2002), concerning my testimony before your committee (February 6, 2002). In C. W. J. Tauzin, Committee on Energy and Commerce, U.S. House of Representatives (Ed.). Washington, D.C.: New York University, Leonard N. Stern School of Business.
- Luthy, D. H. (1998, August 1998). *Intellectual Capital and its Measurement*. Paper presented at the Proceedings of the Asian Pacific Interdisciplinary Research in Accounting Conference (APIRA), Osaka, Japan.
- Luu, N., Wykes, J., Williams, P., & Weir, T. (2001). *Invisible value: the case for measuring and reporting intellectual capital*. Canberra: Department of Industry, Science and Resources, Commonwealth of Australia.
- Mäkeläinen, E. (1998). *Economic Value Added as a Management Tool* [Web site]. Helsinki School of Economics and Business Administration, Department of Accounting and Finance. Retrieved, 2002, from the World Wide Web: [www.evanomics.com/evastudy/evastudy.shmtl](http://www.evanomics.com/evastudy/evastudy.shmtl)
- Malina, M. A. (2001). *Management control and the Balanced Scorecard: An empirical test of causal relations*. Unpublished PhD, University of Colorado, Boulder.

- Mintz, S. L. (1999, May). Seeing Is Believing. *CFO Asia*.
- Nonaka, I., & Takeuchi, H. (1995). *The Knowledge Creating Company: How Japanese Companies Create the Dynasties of Innovation*. New York: Oxford University Press.
- O'Brien, D. J. (2002). *The Value of Knowledge Management* [Web site]. Faculty of Information Technology, University of Technology, Sydney. Retrieved, 2002, from the World Wide Web:  
<http://start.it.uts.edu.au/pgproj/valuekm.pdf>
- Performance Rankings* (1999). [Web site]. Stern Stewart & Co. Retrieved, 2002, from the World Wide Web:  
<http://www.eva.com/performance/overview.shtml>
- Petty, R., & Guthrie, J. (2000). Intellectual capital literature review: Measurement, reporting and management. *Journal of Intellectual Capital*, 1(2), 155-176.
- Phelan, S. E. (1997). Exposing the illusion of confidence in financial analysis. *Management Decision*, 35(2), 163-168.
- Power, M. (2001). Imagining, measuring and managing intangibles. *Accounting, Organizations and Society*, 26, 691-693.
- Roos, J., Roos, G., Edvinsson, L., & Dragonetti, N. C. (1998). *Intellectual capital: navigating in the new business landscape*. New York: New York University Press.
- Salzer-Mörling, M., & Yakhlef, A. (1999). *The Intellectual Capital: Managing by Measure* (Paper submitted to the 1999 Critical Perspective on Accounting Conference). New York: School of Business, Stockholm University.
- Shand, D. (1999, April). Return on Knowledge. *Knowledge Management Magazine*, 1999.
- Shane, H., & Klock, M. (1997). The Relation Between Patent Citations and Tobin's Q in the Semiconductor Industry. *Review of Quantitative Finance and Accounting*, 9(September), 131-146.
- Stewart, T. A. (1997). *Intellectual capital : the new wealth of organizations* (1st ed.). New York: Doubleday / Currency.
- Sveiby, K. E. (1997). *The New Organizational Wealth*. San Francisco: Berrett-Koehler.
- Tapscott (Ed.). (1999). *Creating Value in the Network Economy*. Boston: Harvard Business Review.
- Teece, D. J. (1998). Capturing Value from Knowledge Assets. *California Management Review*, 40(3), 55-79.

Tobin, J. (1969). A General Equilibrium Approach to Monetary Theory. *Journal of Money, Credit and Banking*, 1(1), 15-29.

Wallace, J. S. (1997). Adopting residual income-based compensation plans: Do you get what you pay for? *Journal of Accounting & Economics*, 24(1997), 275-300.